



Installation Instructions **BC-SBC**



www.turbosxs.com
Better By Design

Parts Provided In Kit

- 3 Cable Ties
- 4mm ID Silicon Hose
- Standard Boost Controller

It is recommended that this installation be carried out by a qualified mechanic.

A calibrated boost gauge must be fitted to the vehicle in order that the boost pressure can be monitored as the SBC is adjusted.

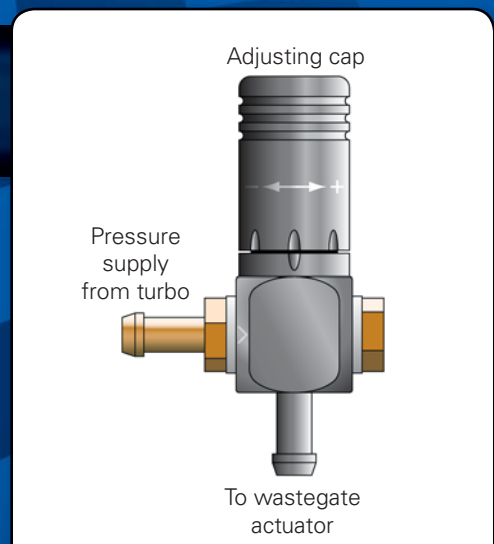

No internal engine components can be warranted at greater than original equipment specifications. This product is for racing use only, and is not applicable or intended for use on emission-controlled vehicles.



1 Turn adjusting cap fully clockwise

Wastegate Actuator



Pressure Source

2 Identify pressure source and disconnect existing controller



3 Connect SBC to pressure source and wastegate actuator

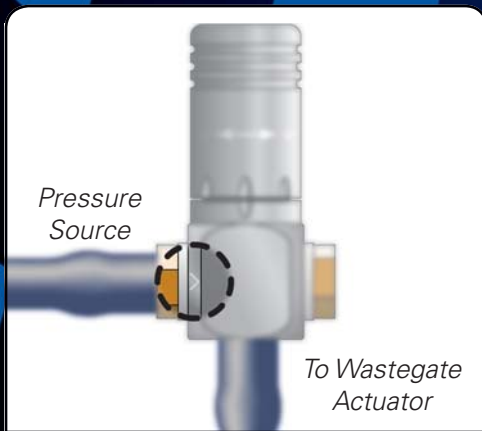

4 Ensure arrow points towards wastegate actuator

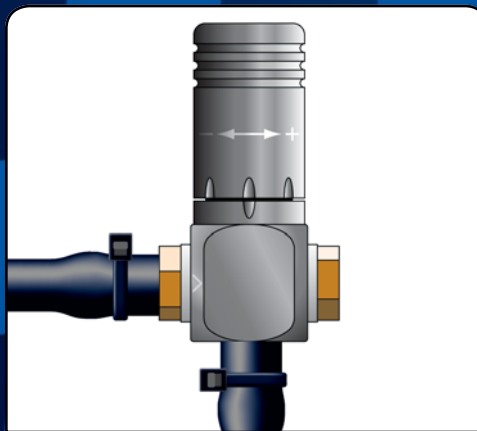

5 Secure all hose connections

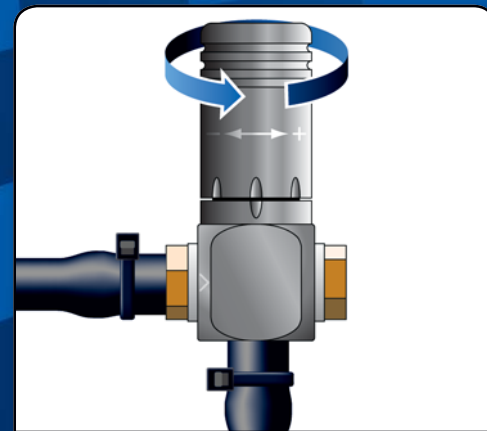

6 Turn counter-clockwise 3 full turns

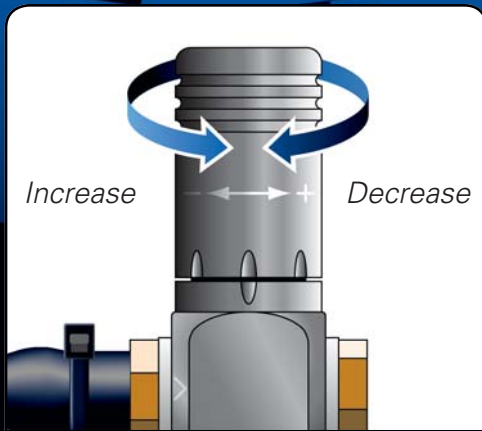

7 Turn cap to adjust boost

⚠ Caution:

Ensure that all pressure hoses are firmly and securely connected. Disconnection will result in a dangerous increase in boost pressure and could lead to engine destruction.

Note:

Factory-installed boost controllers must be disabled or removed prior to the installation of any aftermarket boost controller.

TurboXS USA LLC

ph: 1-877-231-3235
fax: 301-977-6507

TXS Australia Pty Ltd

ph: +612 9987 0395
fax: +612 9987 0129