

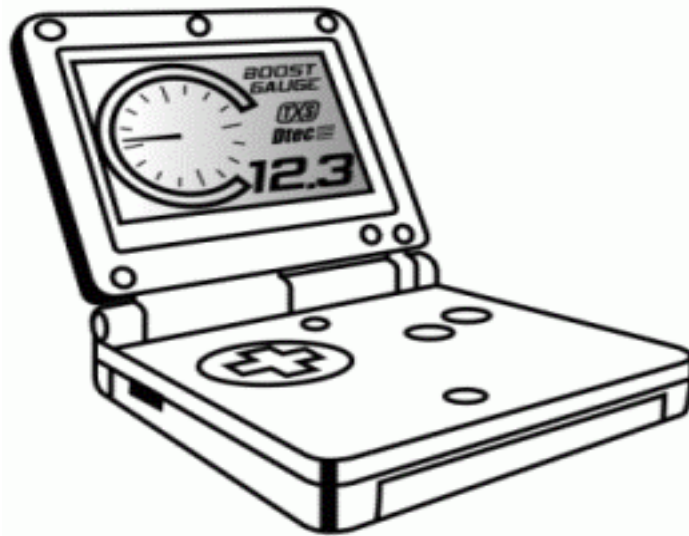

Dtec-BC (Boost Controller) Instruction Manual

Please read this instruction manual to ensure proper use prior to powering up the Dtec. Store this manual inside of the vehicle for future reference. To use the Dtec-BC you will need a Nintendo® Gameboy® Advance SP (GBA).



The Dtec-BC (DBC) allows vehicle monitoring and performance tuning via a handheld Nintendo® Gameboy® console.

Dtec-BC Components List

- Dtec Unit with GBA data and power cables attached.
- TPS & Injector Duty Pickup.
- KnockLite, knock indicator & shift light.
- Boost Control Solenoid
- 3 x 6mm barbed fittings
- 80cm 6mm silicon hose
- 80cm 4mm silicon hose
- 8 x cable ties
- 2 x 4mm T-pieces
- 2 x 6mm T-pieces.
- 4 x 6mm to 4mm hose coupler
- RJ12 Data Transfer Cable.
- Adaptor Connector, 9-way D to RJ12 female.
- Power Input Cable.
- Power Clip for 9-volt battery.
- Velcro with stick back for Dtec, KnockLite and GBA mounting.
- Instruction Manual.
- Application Guide.

Warnings

Important Information

- Read the Manual. Read it again.
- Modifying cars can result in reduced reliability and possible damage
- The Dtec-BC provides more than enough control to destroy your engine
- Use caution and common sense when modifying a vehicle

General Precautions

- This manual is subject to change without prior notification.
- Never adjust the unit while driving.
- Modification of your vehicle may violate laws in your state or country for general road use. The Dtec-BC is recommended for off road or racing purposes only.
- Securely mount Dtec and GBA away from any area that may effect driving.
- Do not mount Dtec or GBA near air bags or areas that the driver or passengers may make contact with in the event of an accident.
- Do not adjust the unit while driving. Obey all road rules & regulations.
- This unit is designed for 12V DC vehicles with negative chassis ground.
- Never disassemble, modify or tamper with this unit.
- Keep this unit away from water and direct sunlight.

ESD (Electrostatic Discharge) Precautions

ESD is the multi thousand-volt zap you feel when you get out of your car on a dry day. This ESD zap can damage electronic devices and should be discharged prior to handling any electronic device. To Prevent ESD, follow the steps below when installing, removing or handling the Dtec:

1. Always turn off the ignition before removing or installing the Dtec.
2. Handle the Dtec as little as possible.
3. Do not slide the Dtec over any surface.
4. Do not touch the connector pins of the Dtec.

Avoid handling the Dtec in areas that have floor or work-surface covering capable of generating a static charge.

Table Of Contents

DTEC-BC OPERATION	4
WHAT IS THE DTEC-BC?	4
TYPICAL DTEC-BC APPLICATIONS	4
<i>Spool Up Optimization</i>	4
<i>Maintain boost</i>	4
HOW THE DTEC-BC WORKS	4
WIRING AND INSTALLATION	5
OVERVIEW	5
IDENTIFYING VEHICLE WIRING	5
IDENTIFYING VEHICLE PNEUMATIC/VACUUM PORTS	5
WIRING DIAGRAM	6
BOOST CONTROL SOLENOID PLUMBING DIAGRAM	7
<i>Conventional Internal Waste-gate Actuator</i>	7
<i>External Waste-gate</i>	7
CONNECTING POWER	8
BOOST CONTROL SOLENOID & MAP SENSOR	8
CONNECTING SENSORS AND SIGNALS	9
SETUP OPTION FOR OWNERS OF THE TXS WIDE BAND TUNER OR TUNER PRO	9
SETUP AND CONFIGURATION	9
POWERING UP THE DTEC-BC	9
DTEC MENU STRUCTURE & KEY STROKE FUNCTIONS	10
<i>Gauges/Displays</i>	10
<i>Select Menu</i>	11
<i>Setup & Calibration Menu</i>	11
SETUP AND SENSOR CALIBRATION	11
<i>TPS Calibration</i>	11
<i>RPM Calibration</i>	12
<i>FCD / Aux In</i>	12
<i>Boost Channel</i>	13
<i>AFR</i>	14
<i>Injector Duty/Scramble Switch/Gear Selection</i>	14
<i>Solenoid Duty</i>	15
<i>Knock Level</i>	15
<i>Saving Parameter Settings</i>	15
EDITING MAPS	16
SELECTING ACTIVE MAP	16
EDITING THE BOOST MAP	16
<i>Basic Boost Setup</i>	16
<i>Advanced Boost Setup</i>	17
COPY MAP	18
CLEAR MAP	18
CONNECTING YOUR DTEC-BC TO A PC	18
TERMINAL PROGRAM SETUP	18
SAVING AND LOADING MAPS TO A FILE	18
DATA RECORDER MENU	20
RECORDING	20
PLAYBACK	20
STOP	20
RECORD PLAYBACK SHORT CUTS	21
DTEC – BC CONFIGURATION RESET	21
DTEC –BC SOFTWARE UPGRADES	21
BASIC TUNING GUIDE	22
TUNING TIPS	22
BOOST CONTROLLER SETUP	22
<i>Open Loop Boost Control</i>	22
<i>Closed Loop Boost Control</i>	22
<i>Tuning Boost</i>	22
PRODUCT SPECIFICATION	23

Dtec-BC Operation

WHAT IS THE DTEC-BC?

The Dtec-BC is a closed loop Electronic Boost Controller that uses feedback from a MAP sensor to control your turbo boost pressure to a precise value. Boost pressure is controlled through the use of an electronically controlled solenoid.

TYPICAL DTEC-BC APPLICATIONS

BOOST OPTIMIZATION

The Dtec-BC can optimize the boost spool up characteristic to ensure that you have maximum boost as early as possible. With the *Closed Loop Controller*, the boost controller is always monitoring your boost pressure and making corrections to target the boost is as close as possible to your chosen target boost pressure.

INCREASING BOOST

An electronic boost controller can be programmed to increase boost over the factory boost setting for your vehicle. The in cabin control also allows you to change boost and setup the unit from within the cabin of the vehicle.

HOW THE DTEC-BC WORKS

The Dtec-BC works by modifying the pressure signal to the turbo waste-gate. On a conventional internal waste-gate, pressure is applied from the manifold to open the waste-gate when the desired boost pressure is reached. By reducing the pressure that reaches the waste-gate, the waste-gate can be kept closed for longer resulting in increased boost.

When the Dtec-BC's closed loop control is activated, the Dtec-BC uses the MAP sensor to measure the boost and will adjust the waste-gate accordingly to increase or decrease boost pressure toward the programmed target boost level.

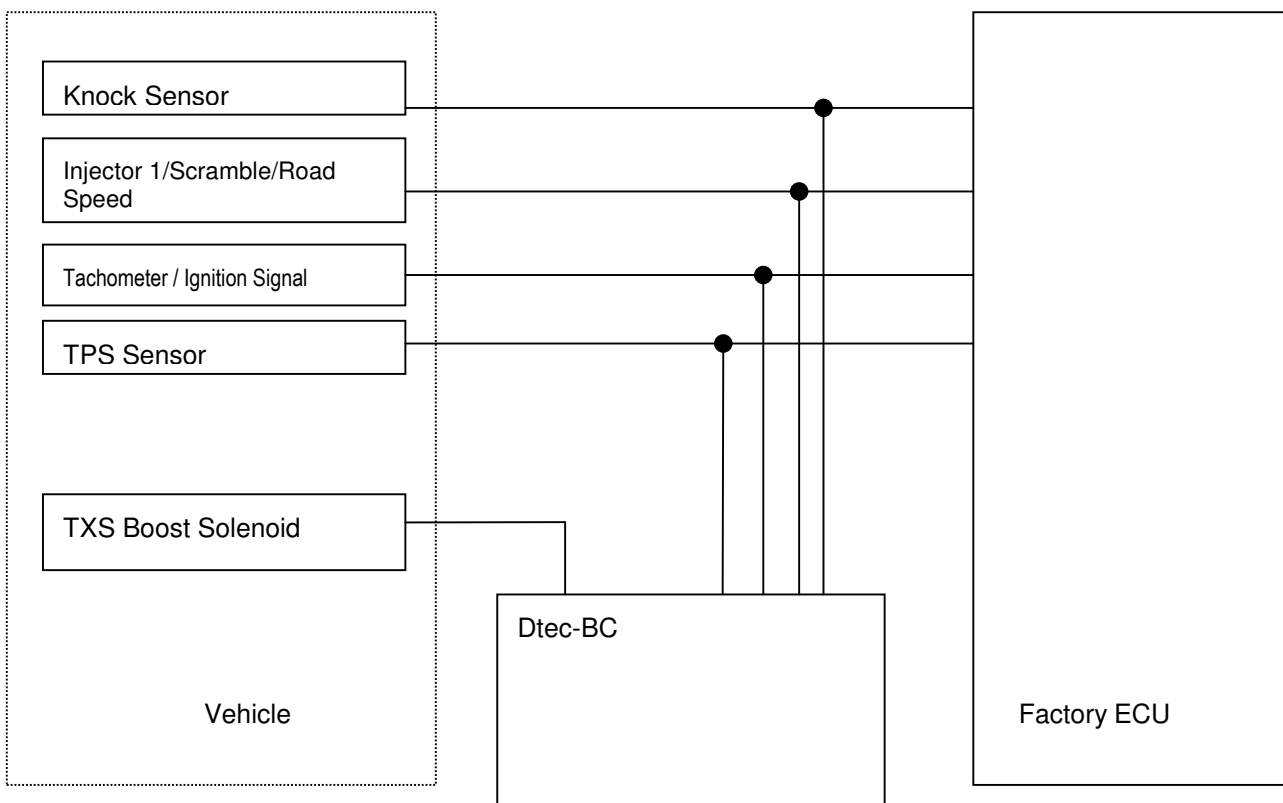

Wiring and Installation

OVERVIEW

1. If you plan to mount the Gameboy® as a display, find a suitable location to mount the Gameboy® display. Ensure that the mounting location does not interfere with driving. Do not mount the Gameboy® display near air bags or in places that may cause injury in the event of an accident. Otherwise, go to step 2.
2. Find a suitable location to mount the Dtec-BC, which has a suitable wiring path to the ECU signal wires.
3. Find a suitable location to mount the TXS Boost Control Solenoid and associated silicon hose plumbing. Connect hoses as per the plumbing diagram below.
4. Find a suitable location to mount the TXS MAP sensor. Connect the MAP sensor to the manifold via the silicon hoses.
5. Identify all the wires that are required to connect the Dtec-BC.
6. Connect Power to the Dtec-BC and test power connection.
7. Connect only the input signals (TPS, RPM, Injector Duty, Knock) to the Dtec-BC and test Inputs. Channels 1& 2. See Diagram below.
8. Connect TXS Boost Control Solenoid and the TXS MAP sensor into channel 4.
9. Optionally, connect TXS Tuner wide band AFR meter and test.
10. Optionally, connect your FCD interface module or Auxiliary Sensor.

IDENTIFYING VEHICLE WIRING

Before wiring the Dtec-BC, you will need to identify the following signal and power wires for your vehicle:

- **Power** Find +12V power that is on when the car's IGN power is on.
- **Ground** Identify a GND wire, alternatively use a good quality connection to the chassis.
- **TPS** The TPS signal on most vehicles will be between 0V and 5V and will vary depending on the throttle position. Identify the TPS signal and trace back to the ECU.
- **RPM** Identify a signal that has regularly spaced pulses that are proportional to engine speed. A typical signal choice would be a tachometer signal or an ignition signal from the ECU to the Ignition Amplifier.
- **Injector** (optional) Use any injector signal. This is used to monitor Injector Duty Cycle and is not essential to the operation of the Dtec-BC.
- **Vehicle Speed** (optional) Use any wheel speed sensor. Required for gear selection detection.
- **Knock** (optional) Splice into the wire between ECU and Knock sensor. This is used to monitor engine knock and is not essential to the operation of the Dtec-BC.

For more details on wiring for specific vehicles, please see the Dtec-BC Application Guide booklet.

IDENTIFYING VEHICLE PNEUMATIC/VACUUM PORTS

Identify the following pneumatic ports on the engine and turbo.

- **Waste-gate** Determine if your turbo waste-gate is an external waste-gate or internal waste-gate. Find the pneumatic ports on the waste-gate actuator.
- **Manifold Pressure** Find a suitable source to measure manifold pressure. Ensure that the MAP sensor measures the true manifold pressure and is not affected by the plumbing of the waste-gate or by the throttle butterfly position. Some throttle bodies have vacuum/boost ports that are open or closed to the manifold depending on the throttle plate position.
- **Air Return** The boost solenoid in certain configurations will bleed off a small (usually negligible) amount of air. For completeness, this air should be returned to the inlet tract after the air flow meter, but before the turbo inlet.

WIRING DIAGRAM

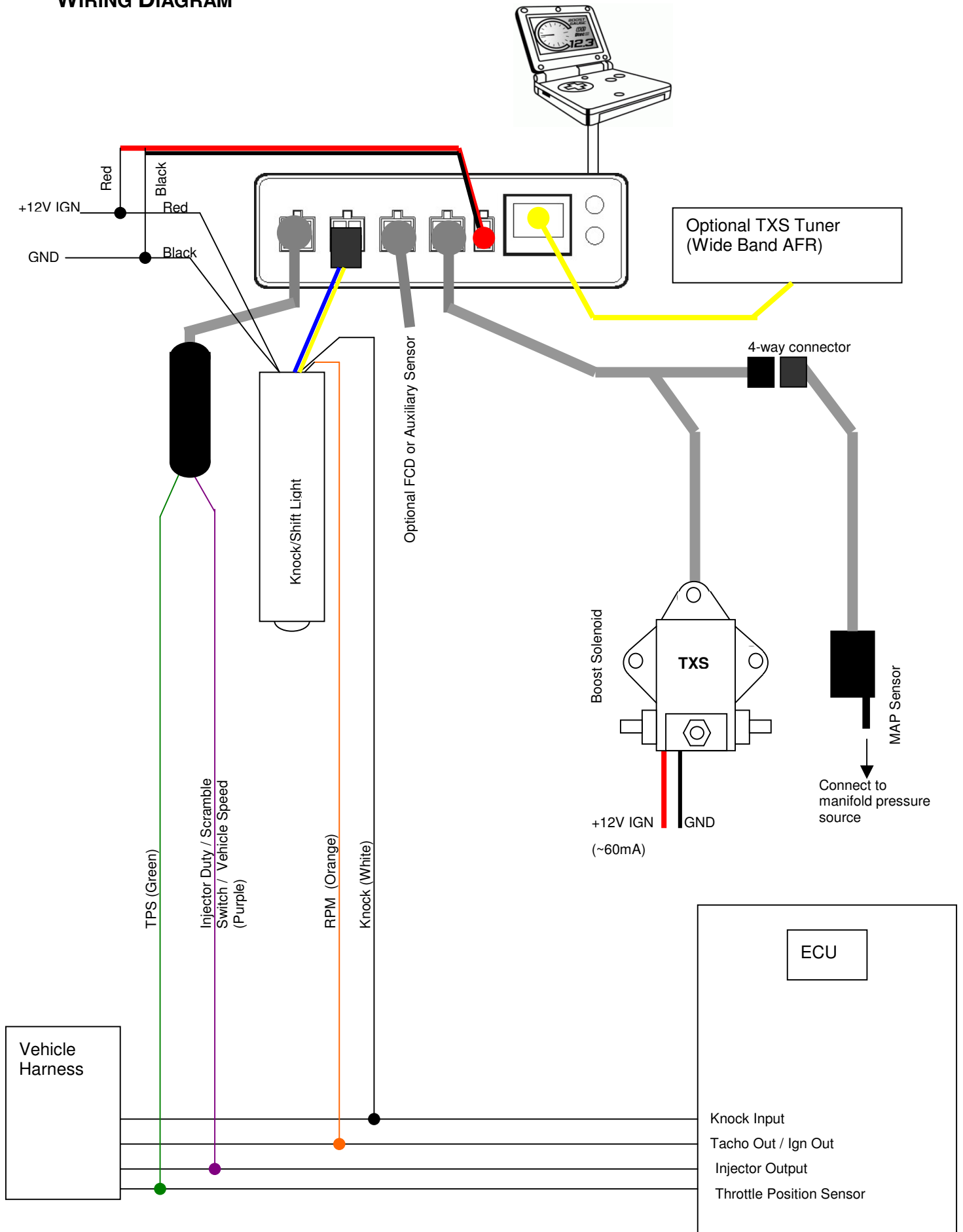

BOOST CONTROL SOLENOID PLUMBING DIAGRAM

CONVENTIONAL INTERNAL WASTE-GATE ACTUATOR

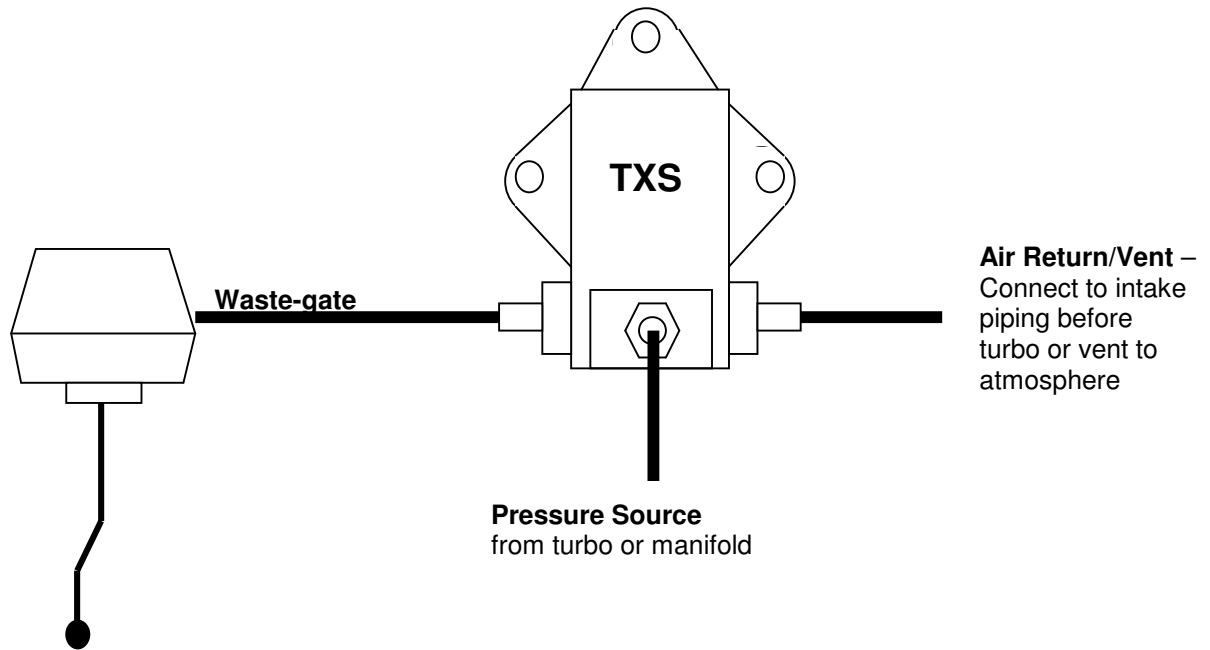

EXTERNAL WASTE-GATE

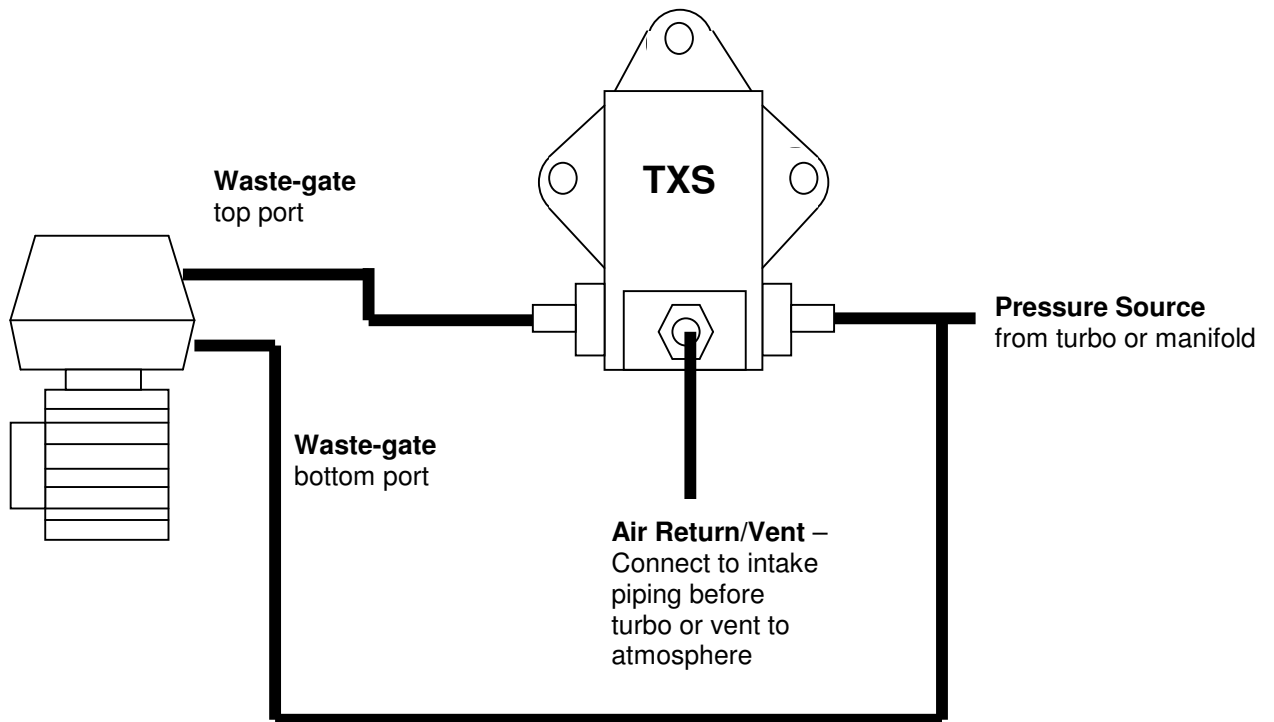

Warning:

- Secure all hoses with cable ties or clamps (including your MAP sensor hose).
- Triple check your waste-gate plumbing.
- A loose hose that falls off under boost can lead to uncontrolled boost and catastrophic engine failure.

CONNECTING POWER

Warning:

- It is always good practice to disconnect the battery when performing any vehicle wiring.
- Always solder connections and insulate the connection after soldering. Poor connections can lead to vehicle damage or poor operation.

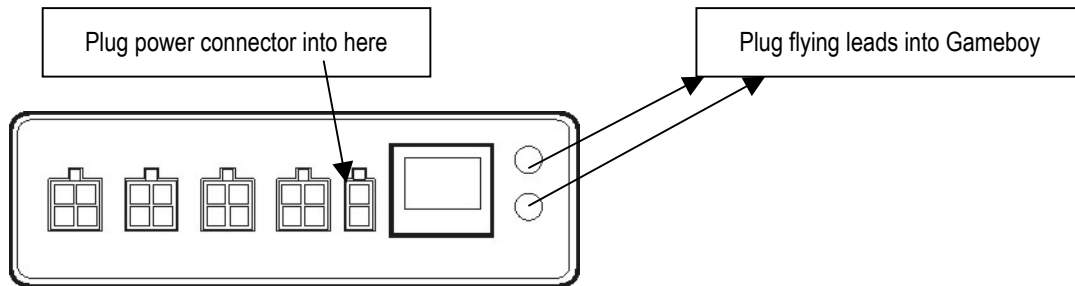

Connect the supplied power cable (Red and Black) using the 2-pin connector to the power socket of the Dtec-BC. After connecting power, plug in your Gameboy® Advance. Turn on vehicle IGN power. The Gameboy® charging light should illuminate. If this does not illuminate, then check your wiring.

BOOST CONTROL SOLENOID & MAP SENSOR

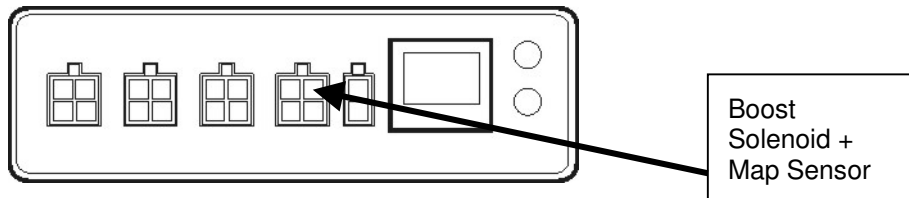

The MAP sensor plugs into the Boost Control Solenoid harness. The whole harness is then plugged into the DTEC-BC.

The Boost Control Solenoid takes requires +12V power and GND to be wired to the solenoid directly. The signal that controls the solenoid comes from the Dtec-BC, but the power used to drive the solenoid comes from the +12V and GND wires. The GND wire can be terminated on ring crimp and connected to a vehicle's chassis GND locally near the Boost Control Solenoid. The +12V should be sourced from a power source that is only on when the vehicle IGN is on. The solenoid draws approximately 60mA maximum current.



Connect the vacuum hoses according to the **Boost Control Solenoid Plumbing Diagram**, and check the MAP sensor reading displays approximately zero pressure when the IGN is on and engine not running. Check that some vacuum is measured when the engine is running at idle.

The default settings of the boost controller will produce low boost on *most cars, but not always!* Please use caution when testing the waste-gate plumbing for the first time.

Note: Incorrect waste-gate plumbing can lead to un-controlled boost, which is very likely to cause engine damage. Please check your vacuum host plumbing carefully and test with caution. Watch your boost gauge carefully at all times during testing.

CONNECTING SENSORS AND SIGNALS

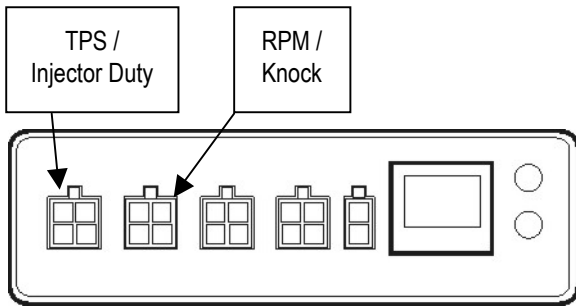

Connect TPS, Injector Duty/Scramble/Road Speed, RPM and Knock signals as per the Wiring Diagram.

Turn on the Gameboy® and wait for the program to load.

Check that there is some change in TPS value while moving the throttle.

Check that there is some non-zero RPM reading that increases with increasing engine speed.

If the Injector Duty option has been connected, check that there is some non-zero Injector Duty reading. This should increase slightly when the engine is revved.

If you have purchased the optional scramble switch, then connect this switch and check that the scramble mode is activated when the switch is pressed.

The knock signal should display zero if your KnockLite is calibrated.

Ignore the calibrations of TPS and RPM for now, these will be calibrated in the next section. If any of the input signals are showing invalid values or not responding, then check your wiring before proceeding.

SETUP OPTION FOR OWNERS OF THE TXS WIDE BAND TUNER OR TUNER PRO

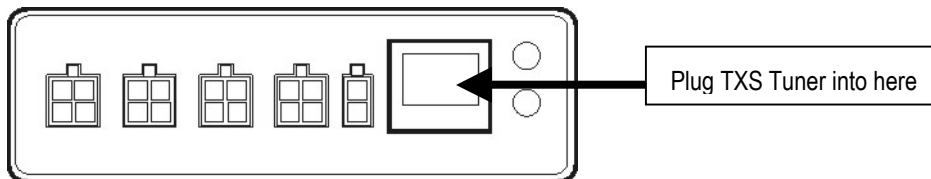

1. Plug one end of the Data Transfer Cable into the RJ12 output connector on the rear face of the TXS Tuner and the other end into the Dtec. (Note: power for the Dtec is supplied via the TXS Tuner).
2. Plug the Data and Power Cables from the Dtec into the rear of the GBA.
3. Turn on the vehicle ignition switch to power up the TXS Tuner. It will take approximately 40 seconds from when the GBA and the Dtec have been turned on for the Dtec to boot the GBA.
4. Press the Up / Down side of the toggle button and the console will scroll from the Boost Pressure screen to the Air Fuel Ratio screen. The number displayed should be the AFR, which appears on your TXS Tuner.

NOTE: Do not use the front serial port (DB9 connector) on your Tuner simultaneously with your Dtec-BC.

Setup and Configuration

POWERING UP THE DTEC-BC

The display and control console for the DTEC-BC is a standard Nintendo® Gameboy® Advance SP (GBA). In order to control the Dtec-BC, the GBA must be booted with software via the cable.

Power up the Dtec-BC by turning on the ignition. Ensure that your Gameboy® is connected via the flying lead connector. Turn on the power to the GBA. The GBA should power up with the Gameboy® Logo, and then begin booting with the Nintendo logo flashing. After approximately 12 seconds, the screen will clear and the DBC program loader will start.

When the program has loaded, the loading status will show 100% and the software will load the maps. When the maps have loaded, the Dtec-BC software will display the last gauge that was selected.

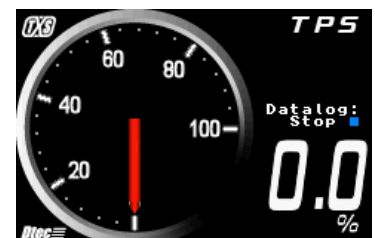
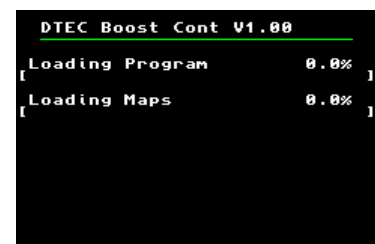

DTEC MENU STRUCTURE & KEY STROKE FUNCTIONS

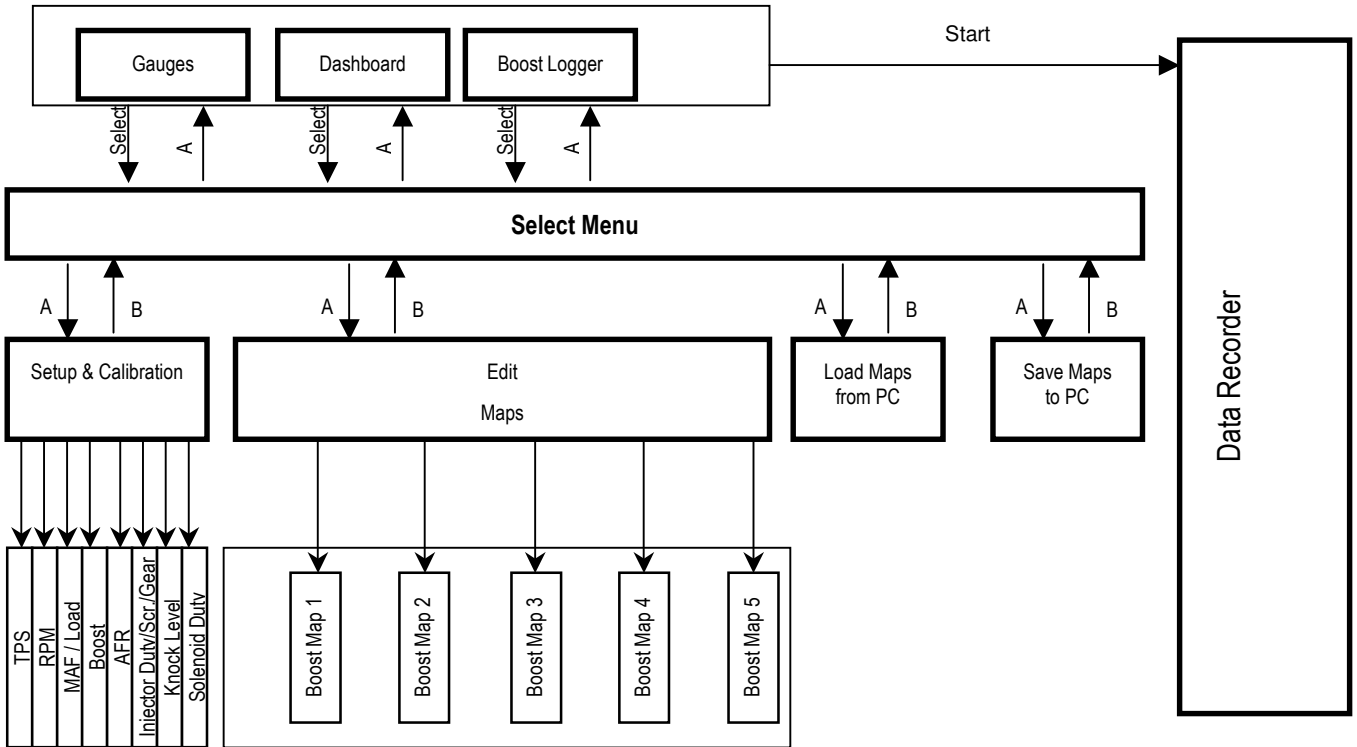

To navigate the various menus, use the 4-way Game-Pad to move the cursor. The bottom of each menu will give you the other key options that can be used to select menus or exit back to a previous menu.

Key options

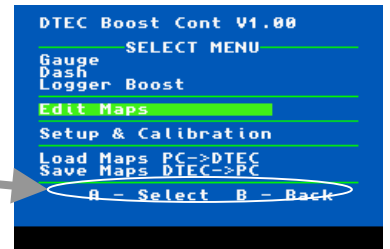

GAUGES/DISPLAYS

GAUGE MODE

The information from the DBC can be displayed in Gauge format.

The 4-way game-pad can be used to scroll through the enabled data channels that are available for display.

- Toggle (Up/Down) - scrolls through Display Screens
- Left/Right – Activate scramble mode.
- “Select” – navigate to the Select Menu from the Display Screen
- “Start” – navigate to and from the Data Record Menu from the Display Screen.

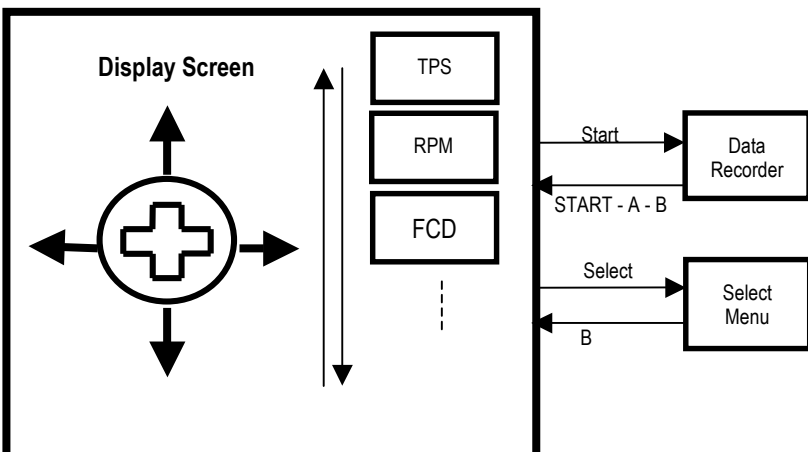

The Select Menu and Data Recorder Menu will be covered in later sections of the manual.

The Dashboard Mode displays the DBC data in plain text format with the numbers being refreshed. This allows an overall view of the state of the vehicle and the inputs to the DBC.

Active keys:

- Select - Display Select Menu
- Start - Display the Data Recorder Menu
- Left/Right – Activate Scramble Mode.

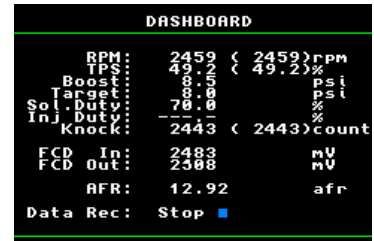

The values displayed in the brackets are the RPM, TPS and Knock count at the last known knock event that exceeded the Last Knock Threshold set in the Knock Level Parameter settings.

LOGGER MODE

Logger Boost

The Logger Boost displays the DBC data in plain text in a log format with newest data scrolling down the screen. This logger is used to aid in setup up the Boost Maps.

Active keys:

- Select - Display Select Menu
- Start - Display the Data Recorder Menu
- Left/Right - Activate Scramble Mode.

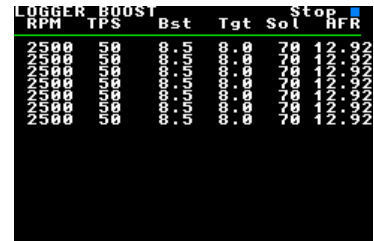

SELECT MENU

The Select Menu is the top level menu that you use to access all the other menu screens of the DBC.

Active keys:

- Toggle (Up/Down) - scrolls through Display Screens
- A - select menu option
- B - back to previous screen

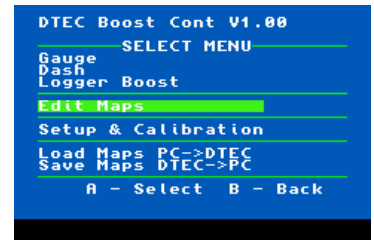

DBC DISABLED WARNING

If you have loaded the DBC software onto a Dtec that has not been enabled for this software, a message will be displayed to indicate that the software is not enabled. However, all gauges and menus will be functional to allow you to preview the software.

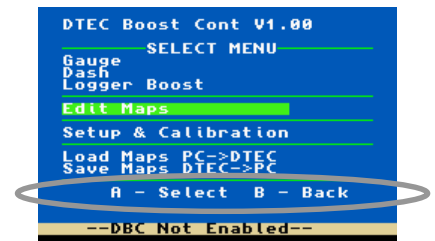

SETUP & CALIBRATION MENU

Enter the Setup Menu by selecting **Setup & Calibration** from the **Select Menu**.

In the Setup Menu you can turn off/disable any of the channels so they are not active when scrolling through the Display Screens.

Move the cursor over to the Enabled column and change a channel's enable status to "On" or "Off" by pressing the "A" button to enable or disable that channel.

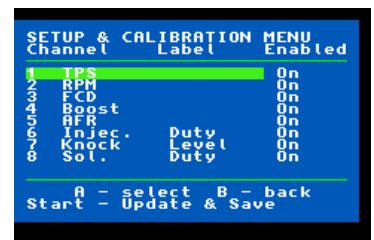

To enter the Parameter Menu highlight the channel you wish to configure and press the "A" button. This will take you to the Parameter Menu.

SETUP AND SENSOR CALIBRATION

For each type of data that can be displayed on the Dtec-BC Gauges or Displays, there is a Setup and calibration Screen that is used to determine how the data appears on the Gauges and, depending on the data channel, there may be calibration and setup options for that channel.

TPS CALIBRATION

The TPS calibration can be performed manually by setting **TPS Min 0%** and **TPS Max 100%** parameters, or by selecting the **Automated TPS** calibration option.

- **Automated TPS** – Select the Calibrate option to start the automated TPS calibration process. Follow the instructions on the screen.

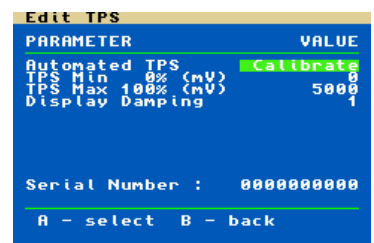

- **TPS Min 0% (mV)** – The voltage that the TPS sends out when the throttle plate is in the closed position.
- **TPS Max 100% (mV)** – The voltage that the TPS sends out when the throttle plate is in the fully open position.
- **Display Damping** – This determines the amount of damping for the displayed data. The higher the number the smoother the output signal at the expense of transient response. This parameter only affects the display, and does not affect any calculations in the Dtec-BC.

RPM CALIBRATION

The RPM calibration allows you to calibrate your RPM to account for the number of pulses that the Dtec-BC receives for every complete engine cycle (2 engine revolutions on 4 stroke engines). If you are unsure, then use the Auto Cal option, which will select the correct number of pulses.

PARAMETER	VALUE
Gauge Min (rpm)	0
Gauge Max (rpm)	8000
Gauge Major Div	8
Gauge Multiplier	x1000
Pulses per Cycle	4
Display Damping	Auto Cal

A - select B - back

- **Gauge Min (rpm)** – The minimum RPM that will be displayed on the gauge face.
- **Gauge Max (rpm)** – The maximum RPM that will be displayed on the gauge face.
- **Gauge Major Div** – Defines the number of major divisions on the gauge.
- **Gauge Minor Div** – Defines the number of minor divisions on the gauge.
- **Gauge Multiplier** – Allows larger numbers to be set and displayed on the gauge by displaying a gauge multiplier. E.g. If a gauge number was '8000', using the x1000 option would display x1000 on the gauge face, and the gauge number would now display as '8'.
- **Pulses per Cycle** – This is the number of pulses per engine combustion cycle. This is 2 revolutions of the engine in most automotive 4-stroke engines. Typically, this value will be the number of cylinders that the engine has. For example, a 4-cylinder car will usually have 4 pulses per cycle for a tachometer signal.
- **Pulses per Cycle Auto Cal** – Select this option to have the Dtec-BC assist in selecting the Pulses Per Cycle number. This is done holding the engine at 2000rpm while the Dtec-BC examines the RPM signal.
- **Display Damping** – This determines the amount of damping for the displayed data. The higher the number the smoother the output signal at the expense of transient response. This parameter only affects the display, and does not affect any calculations in the Dtec-BC.

FCD / AUX IN

FCD SETUP

The Dtec-BC allows the option of a Fuel Cut Defend (FCD) on the spare channel. Extreme caution must be exercised when using the FCD. Only use this option if you are really sure that you need to use it. Leave both values set to 5000.00mV to keep the FCD disabled.

PARAMETER	VALUE
Input Type	FCD
Display Damping	3
I/O Filtering	0
FCD Limit (mV)	+5000.00
FCD Restore (mV)	+5000.00

!!! Use FCD with CAUTION !!!
! Misuse can damage engine !

A - select B - back

The FCD option is used to clamp the signal from the factory MAP sensor in order to allow an increase in boost pressure without triggering the ECU's Fuel Cut mechanism.

- Input Type** Set this to FCD when using the Fuel Cut Defend option.
- Display Damping** The amount of damping or averaging for the gauge display.
- I/O Filtering** If the MAP sensor signal bounces around a lot and trips the FCD circuit when it shouldn't, then increase the I/O Filtering.
- FCD Limit** The maximum voltage from the MAP sensor before Fuel cut is triggered. E.g. If you are increasing boost to 18psi and the factory ECU cuts fuel at 15psi, then set this to the voltage that is recorded when at 15psi.
- FCD Restore** The voltage corresponding to the new fuel cut boost that you wish to run. When this voltage is reached, the FCD will restore the voltage to the ECU and will cut fuel. E.g. if you are running 18psi, then set this to the voltage that is recorded when 18psi is exceeded. If prefer fuel cut to never occur, then set this 5000mV.

AUX IN

The spare channel can be used as an input for an auxiliary gauge such as an Exhaust Gas Temperature sensor, or Air Intake Temp sensor. The Auxiliary Gauge channel can be fully customized and calibrated.

PARAMETER	VALUE
Input Type	Aux. Gauge
Label 1 (7 char)	Aux
Label 2 (6 char)	In
Units (4 char)	mV
Gauge Major Div	5
Gauge Minor Div	5
Offset (mV)	+ 0.00
Display Damping	3

NEXT PAGE

A - select B - back

Page 1 Parameters

- Input Type** Set this to *Aux. Gauge* when an Auxiliary sensor is connected to channel 3.

- Label 1 (7 char)** The 1st line of the text label used to describe the information displayed on this channel. Up to 7 characters can be used for the label.
- Label 2 (6 char)** The 2nd line of text label used to describe the information displayed on this channel. Up to 6 characters can be used for the label.
- Units (4 char)** The text label used to describe the units for the information displayed on this channel. Up to 4 characters can be used for the label.
- Gauge Major Div** Defines the number of major divisions on the gauge. " 6 "
- Gauge Minor Div** Defines the number of minor divisions between the major divisions on the gauge. " 5 "
- Offset** Defines the offset value required to set the zero calibration point of the output. This can be used to make small adjustments to the calibration. Default is "0.00"
- Display Damping** This determines the amount of damping for the displayed data. The higher the number, the smoother the output signal at the expense of transient response. This parameter only affects the display, and does not affect any calculations in the Dtec-BC.

NEXT PAGE - takes you to the second Parameter Menu page.

Page 2 Parameters

PREV PAGE – takes you to the first Parameter Menu page.

- Gauge Min** Defines the minimum (6 o'clock) number on the gauge.
- Gauge Max** Defines the maximum (3 o'clock) number on the gauge.
- Gauge No DP** Defines the number of decimal places for the numbers on the gauge.
- Gauge Multiplier** Allows larger numbers to be set and displayed on the gauge by displaying a gauge multiplier.
- Digital Number DP** Defines the number of decimal places on the Digital Number for both the Gauge and Data Log Mode.
- Cal 1 Input** Defines the input value of the sensor with regards to its Cal 1 output. Set as per the sensor calibration sheet.
- Cal 1 Output** Defines the output value of the sensor with regards to its Cal 1 input. Set as per the sensor calibration sheet.
- Cal 2 Input** Defines the input value of the sensor with regards to its Cal 2 output. Set as per the sensor calibration sheet.
- Cal 2 Output** Defines the output value of the sensor with regards to its Cal 2 input. Set as per the sensor calibration sheet.

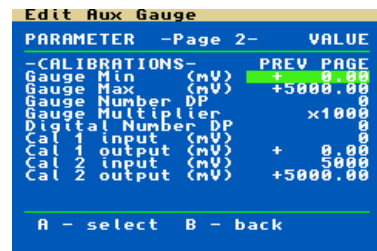

BOOST CHANNEL

BOOST CHANNEL SETUP

The Parameter Menu allows you to set the calibration points for the input sensor plugged into that channel and configure some of the display aspects of the Display Screen.

Enter the Boost setup menu from the Setup & Calibration Menu by pressing the "A" button and return by pressing the "B" button.

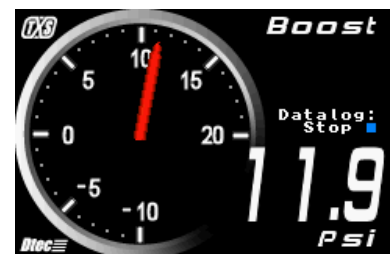

Page 1 Parameters

Move the cursor to the appropriate parameter you wish to edit and press the "A" button. Press the "B" button to return to the Parameter Menu.

- Gauge Major Div** Defines the number of major divisions on the gauge. "6"
- Gauge Minor Div** Defines the number of minor divisions between the major divisions on the gauge. " 5 "
- Offset** Defines the offset value required to set the zero calibration point of the output. This can be used to make small adjustments to the calibration. Default is "0.00"
- Display Damping** This determines the amount of damping for the displayed data. The higher the number, the smoother the output signal at the expense of transient

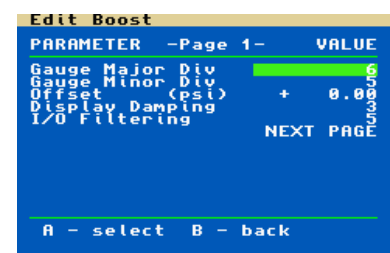

response. This parameter only affects the display, and does not affect any calculations in the Dtec-BC.

I/O Filtering This determines the amount of noise filtering for the MAP signal that is used for the actual boost controller, as opposed to the display.

NEXT PAGE – takes you to the second Parameter Menu page.

Page 2 Parameters

PREV PAGE Takes you to the first Parameter Menu page.

Gauge Min Defines the minimum (6 o'clock) number on the gauge.

Gauge Max Defines the maximum (3 o'clock) number on the gauge.

Gauge No DP Defines the number of decimal places for the numbers on the gauge.

Gauge Multiplier Allows larger numbers to be set and displayed on the gauge by displaying a gauge multiplier.

Digital Number DP Defines the number of decimal places on the Digital Number for both the Gauge and Data Log Mode.

Cal 1 Input Defines the input value of the sensor with regards to its Cal 1 output. Set as per the sensor calibration sheet.

Cal 1 Output Defines the output value of the sensor with regards to its Cal 1 input. Set as per the sensor calibration sheet.

Cal 2 Input Defines the input value of the sensor with regards to its Cal 2 output. Set as per the sensor calibration sheet.

Cal 2 Output Defines the output value of the sensor with regards to its Cal 2 input. Set as per the sensor calibration sheet.

NOTE: The numbers on the gauge are scaled according the Min & Max gauge values and the number of major divisions.

$(\text{Gauge Max} - \text{Gauge Min}) / \text{Major Divisions} = \text{Increment Size}$

$20 - (-10) = 30 / 6 = 5 \text{ psi between major divisions.}$

AFR

The AFR parameters allow adjustment of the gauge display.

Gauge Min – defines the minimum (6 o'clock) number on the gauge.

Gauge Max – defines the maximum (3 o'clock) number on the gauge.

Gauge Major Div – defines the number of major division on gauge. " 5 "

Gauge Minor Div – defines the number of minor divisions between the major divisions on gauge. " 5 "

Gauge No DP – defines the number of decimal places for the numbers on the gauge.

PARAMETER	VALUE
-CALIBRATIONS-	
Gauge Min (psi)	10.00
Gauge Max (psi)	20.00
Gauge Number DP	
Gauge Multiplier	x1
Digital Number DP	1
Cal 1 input (mV)	1157
Cal 1 output (psi)	7.53
Cal 2 input (mV)	1711
Cal 2 output (psi)	20.28

A - select B - back

PARAMETER	VALUE
Gauge Min (afr)	10.00
Gauge Max (afr)	20.00
Gauge Major Div	5
Gauge Minor Div	5
Gauge Number DP	0

A - select B - back

INJECTOR DUTY/SCRAMBLE SWITCH/GEAR SELECTION

INJECTOR DUTY

Input Type – Set the input type to reflect what is wired to this input. When connected to an injector signal, set to Inj.Duty.

Display Damping – This determines the amount of damping for the displayed data. The higher the number the smoother the output signal at the expense of transient response. This parameter only affects the display, and does not affect any calculations in the Dtec-BC.

Scramble Override – When set to Enabled, scramble mode is permanently activated. By default, it is disabled to allow scramble activation by pressing the Left or Right on the Gameboy 4-way keypad while on a gauge screen.

PARAMETER	VALUE
Input Type	Inj.Duty
Display Damping	2
Scramble Override	Disabled

A - select B - back

GEAR SELECTION

Input Type – Set the input type to reflect what is wired to this input. When connected to a Vehicle Speed Signal, set this input type to Gear Sel. When this input is set to Gear Sel., the 5 Boost maps are assigned to each gear, and the active map will depend upon which gear is selected.

Gear Calibration – Select this option to calibrate your vehicle speed vs. RPM to allow gear selection. Press 'Start' to begin the calibration. Drive in

each gear and press 'A' to assign the calibration number to the Gear Calibration. If you have a 4-speed gearbox, you can skip the 5th gear calibration by pressing 'Select'.

Scramble Override – When set to Enabled, scramble mode is permanently activated. This allows you to use the scramble map as a second set of high boost maps.

By default, it is disabled to allow scramble activation by pressing the Left or Right on the Gameboy 4-way keypad while on a gauge screen.

SCRAMBLE SWITCH

Input Type – Set the input type to reflect what is wired to this input. When connected to a cabin mounted switch for Scramble activation, set this input to 'Scramble'.

Scramble Hold (sec)– Set this to the number of seconds that you wish the Scramble mode to remain active for, *after* releasing the Scramble switch. If you wish to have Scramble boost active only whilst the switch is held down, then set this time to zero. While scramble mode is active, the Gauge screen background will flash blue. This timer also applies to the Gameboy activation via the Left & Right directions on the 4-way keypad.

Scramble Override – When set to Enabled, scramble mode is permanently activated. By default, it is disabled to allow scramble activation by pressing the Left or Right on the Gameboy 4-way keypad while on a gauge screen.

SOLENOID DUTY

Solenoid Output – When set to Enabled (default), the boost controller will cycle the solenoid to control boost. When set to Disabled, the solenoid will remain in the de-energized position, which should result in minimum boost as determined by the waste-gate spring pressure.

KNOCK LEVEL

Last Knock Thresh - This is the number of knock counts that must be detected before the Dash display will register and record the last known knock event.

SAVING PARAMETER SETTINGS

If you have made changes to any channel parameters, then as you exit the Setup & Calibration Menu, you will be prompted to save your changes.

If you wish to force a save regardless of changes, press the "START" button.

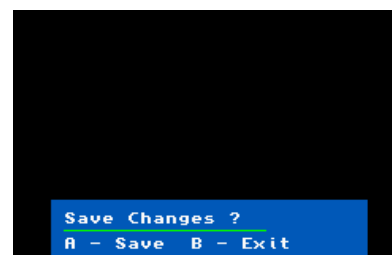
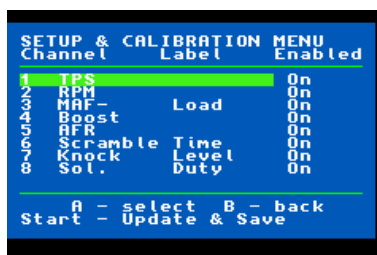
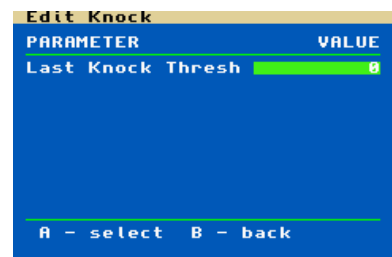
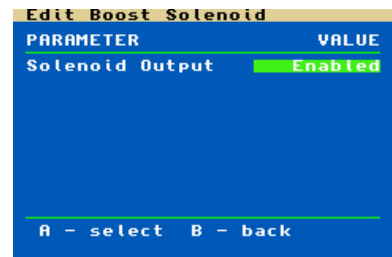
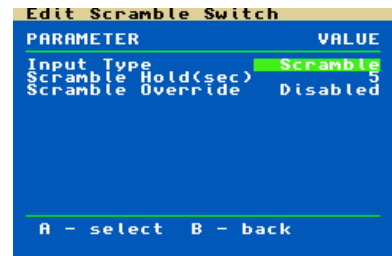
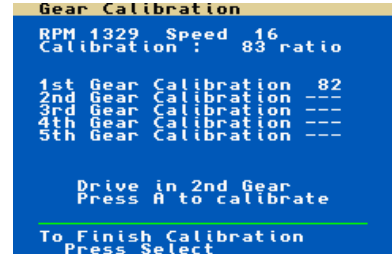
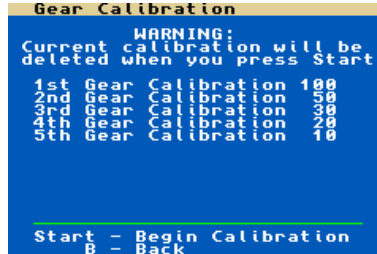
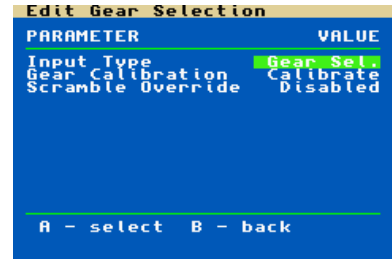

Editing Maps

SELECTING ACTIVE MAP

The Map with the <- indicator is the active map which the Dtec-BC will use for its calculations for modifying the amount of boost.

The Dtec-BC allows 5 separate boost maps. To change the active map, move the cursor up to map you wish to activate and simultaneously press 'L' and 'R' keys.

At the **Edit Maps** window, choose which map you wish edit by pressing 'A'.

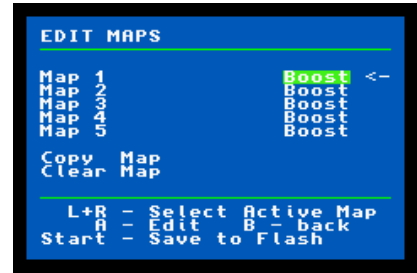

EDITING THE BOOST MAP

BASIC BOOST SETUP

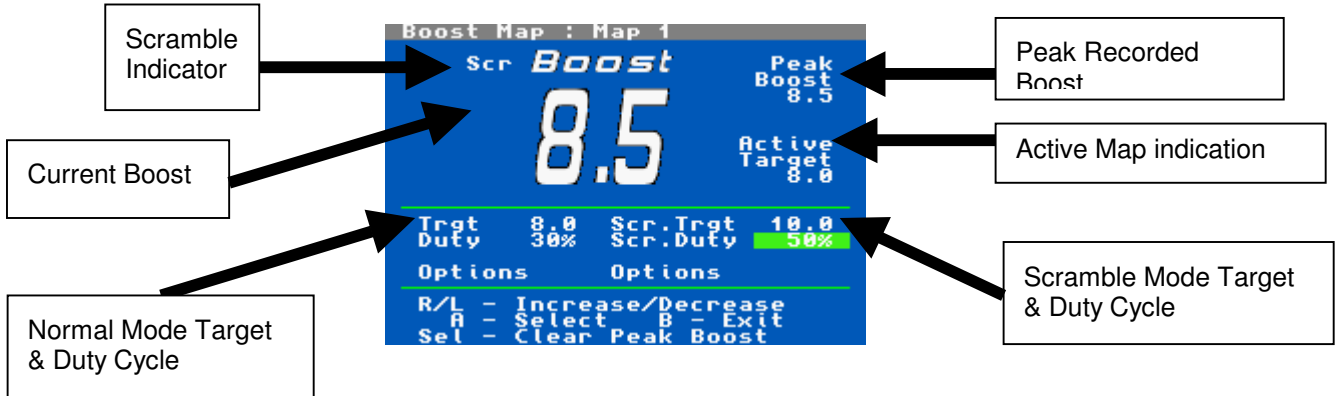

CURRENT BOOST

The current boost pressure.

PEAK BOOST

The peak boost pressure recorded while this screen is displayed. To reset this value to zero, press the 'Sel' button.

ACTIVE MAP INDICATION

When the 'Active Target' appears, this indicates that you are editing the current active map. If you are editing a map that is not the active map, then this will not appear.

NORMAL MODE

Target

Choose the boost that you wish to run for this map in the normal mode. Use the L and R keys to increment or decrement the number to set the value.

Duty Cycle

A 0% duty cycle should produce the minimum boost level as determined by the waste-gate. The lowest setting is 5% duty, which should increase boost a negligible amount. Start with a low duty cycle and slowly increase the duty until the boost (as displayed on the Current Boost indicator) is close to the Target Boost. The Peak Boost indicator can be used to assist in determining what maximum boost is achieved. To reset the Peak Boost indicator, press the 'Select' button.

If the boost response is satisfactory, then you may finish the setup here.

Options

If there is some boost drift or some boost fall off, then the closed loop controller can be enabled via the Options menu.

- Controller Gain** – When set to zero, the boost controller runs in open loop mode and controlled purely by the Duty Cycle setting. To enable the closed loop controller, slowly increase this value until the boost begins to oscillate. You will feel the car surging on boost when this happens. Reduce the gain until the oscillation stops. Higher gears are more susceptible to oscillations than lower gears.

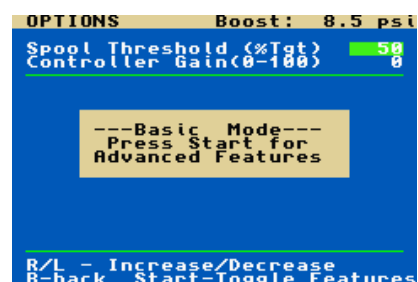
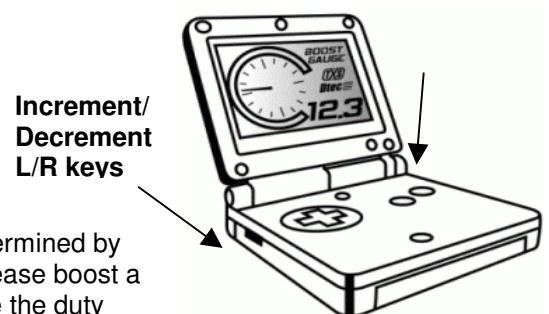

- **Higher Gain** – Faster closed loop boost controller response, less stable boost.
- **Lower Gain** – Slower closed loop boost controller response, more stable boost.
- **Spool Threshold** – To aid in turbo spool up, the Spool Threshold determines how long the boost controller will hold at 99% duty before reverting to the preset Duty and close loop control (if enabled). The value is a percentage of the target boost. E.g. 50 represents 50%. If the Target is 10psi, then the boost solenoid will start at 0% duty off boost, 99% when boost begins until 50% x 10psi = 5psi of boost. At which point, the controller will take over from 5psi to 10psi. If boost is within 3psi of the target, the controller will override the 99% duty to avoid excessive boost spiking.

SCRAMBLE MODE

Scramble mode is a temporary high boost setting. The setup for Scramble Mode is identical to the Normal mode. The settings for Scramble are used when Scramble mode is activated by

1. The external scramble switch (if configured).
2. Pressing the Left or Right directions on the 4-way keypad on the Gameboy
3. Enabling the 'Scramble Override' option in the Injector Duty/Gear Selection/Scramble switch setup.
4. When editing the scramble Target, Duty or Options, the Scramble mode will be active.

ADVANCED BOOST SETUP

If the Basic Boost mode does not control boost satisfactorily, then Advanced Boost mode can be activated to allow greater control of the boost characteristics.

BOOST TABLE

The Boost Table allows the Target Boost and Duty Cycle to change over RPM.

The ability to map Duty Cycle across RPM allows you to compensate for boost that may vary across engine RPM.

- If boost dips below the target boost for a given RPM range, then increase Duty Cycle for that RPM to compensate for the dip.
- If boost spikes above the target boost for a give RPM range, then decrease Duty Cycle for that RPM range to compensate for the spike.

The RPM points can be changed to suit the RPM range of the engine. To change these points, move the cursor to the 'Target (psi)' column, then press and hold the Game-pad left until the cursor jumps into the RPM points column.

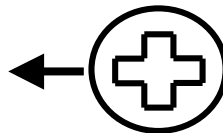

Hold

ECU CLOSED LOOP BOOST

If you do not understand the following description on how to use these settings, then leave these settings at their default.

Some ECU's operate in closed loop fuel control mode until a certain TPS threshold is reached. During this mode of operation, an ECU will try to target an Air-Fuel Ratio of 14.7:1 for economy. If boost is increased in this region, the engine may begin to knock/detonate. To ensure that boost is kept to an acceptable level in this region, you may set a boost level with these settings. These settings are used across all maps.

- **C.Loop TPS** – The TPS threshold, under which the C.Loop Target and C.Loop Duty will be used.
- **C.Loop Target** – The Target Boost that will be used when TPS is less than C.Loop TPS.
- **C.Loop Duty** – The Duty Cycle that will be used when TPS is less than C.Loop TPS.

FEEDBACK DELAY

The feedback delay is the time it takes from changing the boost control solenoid's duty cycle, until the corresponding change in boost is detected by the MAP sensor. The Feedback Delay is in milliseconds. If you have a short intake path and a small responsive turbo, then this value will be lower. If you have a large turbo with a long intake path, then this value will be larger.

- Lower value -> faster closed loop boost controller response, but less stable.
- Higher Value -> slower closed loop boost controller response, but more stable.

COPY MAP

From the Edit Map Menu, you can choose to copy a Map over another map. This allows you to copy your maps and switch between two maps for an 'A-B' comparison between maps. Follow the on screen instructions to copy a map.

CLEAR MAP

From the Edit Map Menu, selecting the Clear Maps option will reset a map back to factory default. Clearing a map will only reset the map that you select.

Connecting your Dtec-BC to a PC

Unplug your TXS Tuner from the Dtec-BC if this is plugged into the Dtec-BC's serial port.

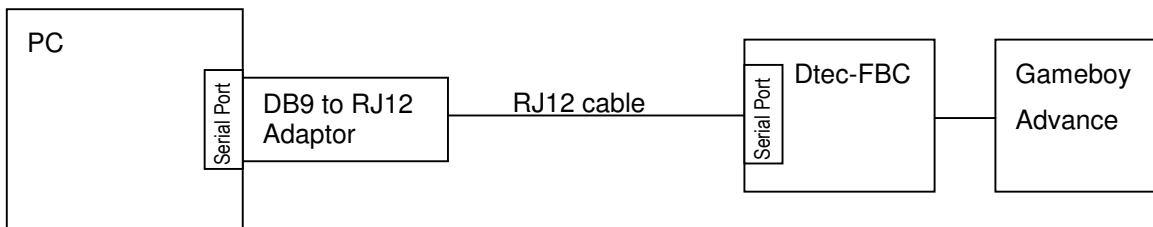

TERMINAL PROGRAM SETUP

To Save and Load maps to a PC, you will need a Terminal program running on the PC. The terminal program should be configured for:

- RS232 Serial Communications
- 19200 baud
- No Parity
- 1 stop bit
- No flow control
- VT100 terminal emulation

Most PC's running Windows® 98, Windows 2000 or Windows XP operating system should have HyperTerminal installed which can be configured to work with the above settings.

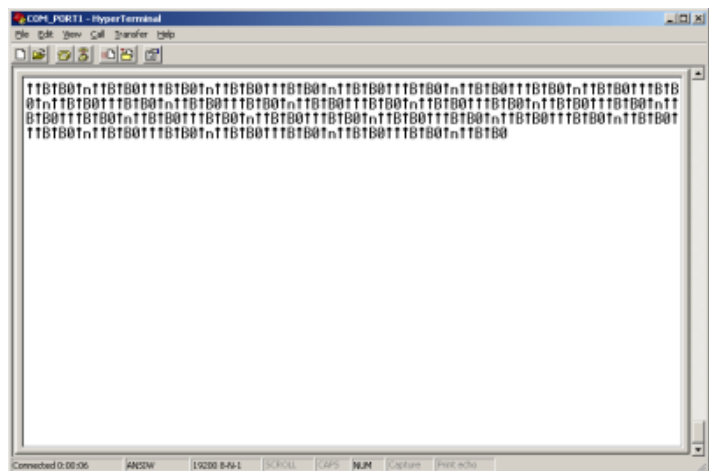

When connected to the Dtec-BC, the screen may be filled with "B0" characters. This is normal.

SAVING AND LOADING MAPS TO A FILE

SAVING MAPS

Once you have your Dtec-BC connected to your PC and the appropriate Terminal software running, you can save your maps from your Dtec-BC by selecting the **Save Maps DTEC->PC** option from the Select Menu. Once you have selected this option, the terminal display will show the screen as shown in the screenshot.

Follow the instructions on the Terminal screen. While the map is being transferred, you will see characters appearing in the lower left hand corner of the screen. When the transfer has

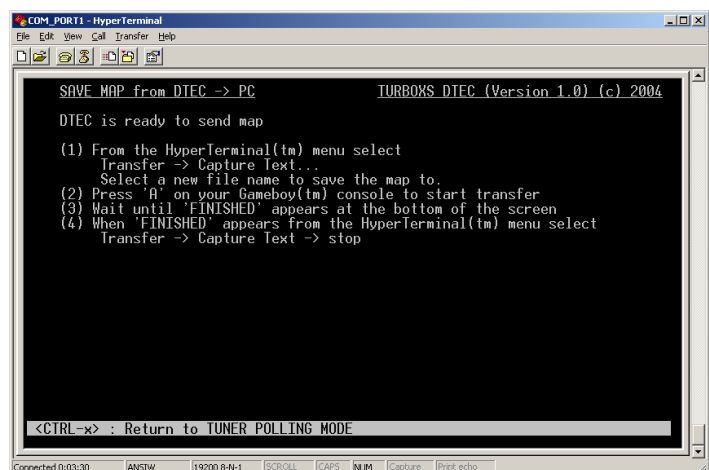

finished, the word "FINISHED" will be left on the lower left hand corner of the screen.

After completing the last step in the instructions, press **B** on the Gameboy® to exit the Save Map menu.

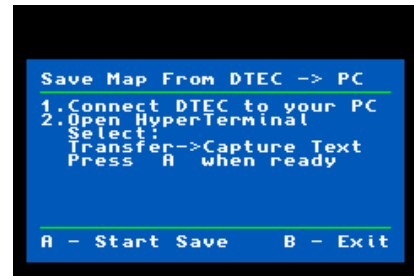

LOADING MAPS

Once you have saved a map to your PC, you can load the map using a Terminal program on your PC. Connect your PC to your Dtec-BC as described in the section above, then select **Load Maps PC->DTEC** option from the Select Menu. Once you have selected this option, the terminal display will show the screen as shown in the screenshot.

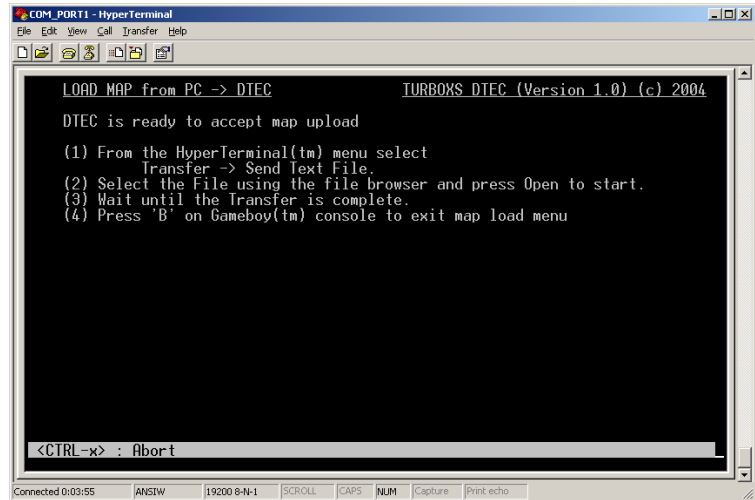

Follow the instructions on the Terminal screen. While the map is loading, a 'Percentage Complete' indication will be displayed to show the progress of the map loading.

When the map has completed loading, the map's Checksum will be calculated to ensure that the map is not corrupted.

If the map loads successfully, the message **'Map load OK'** will be displayed.

If the map fails the Checksum test, then an error message **'Checksum Failed'** will be displayed.

If the 'map load' fails to complete within a timeout period, then an error message **'File Load Timeout'** will be displayed.

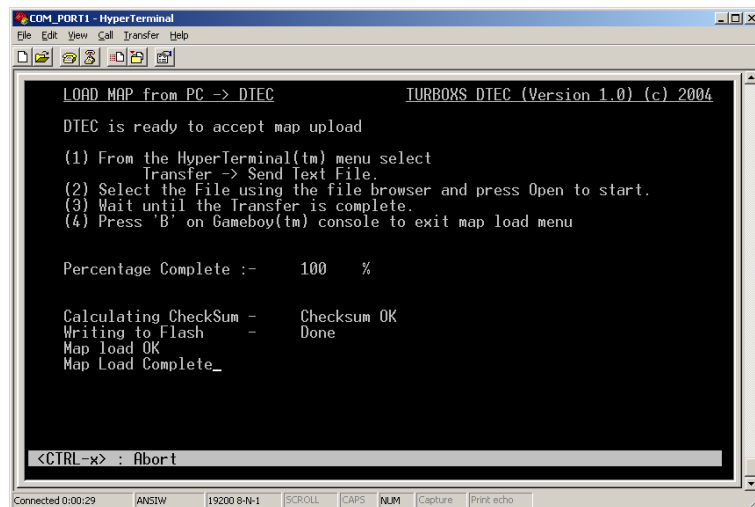

After the map has finished loading successfully, the Load Map menu on the Gameboy® will display a message **'Map Load OK'** on the screen. If there was a checksum error, the Load Map menu will display **'Map Failed Checksum Test'**. If the map load fails to complete within the timeout period, the Load Map menu will display **'Map Load Timeout'**.

When map loading is complete, press **B** to exit back to the Select Menu.

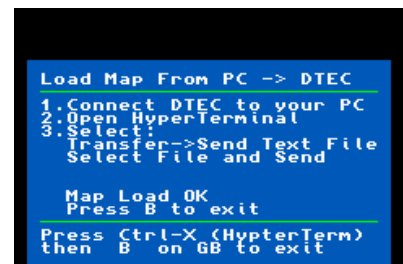

Data Recorder Menu

The Data Recorder Menu is accessed via the Display Screens or Edit Map screens by pressing the “**Start**” button.

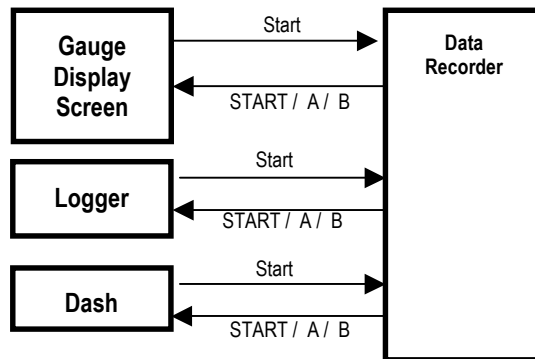

Move the cursor to the appropriate function and press “**START**” or “**A**” to activate and return to the Display Screen. Press “**B**” to return back to the Display Screen without activating the function.

The data recorder behaves similar to a Tape recorder or VCR. The Data Recorder status is displayed on all Gauges and Data Displays.

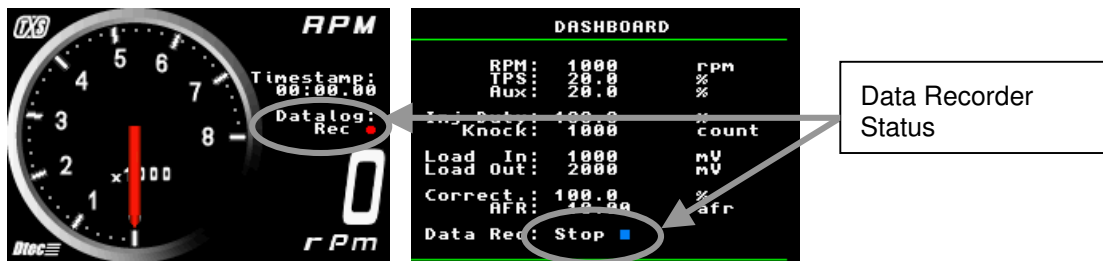

The Edit Maps screen Engine Data Display panel and lower Status Bar also change colour to green to further emphasize that the data recorder is active.

RECORDING

When Recording is activated, a Timestamp will be displayed on the screen, and the live data being captured is displayed on the gauge or data screen.

If a fresh recording is started from the Stop or Play modes, then the Timestamp will be reset to zero at the beginning of a new recording.

A recording can be paused and resumed by pressing the **A** key or by selecting Pause from the Data Recorder Menu. When a recording is paused, the Timestamp will continue to run, so upon playback, you will see a jump in the Timestamp while the recording was paused.

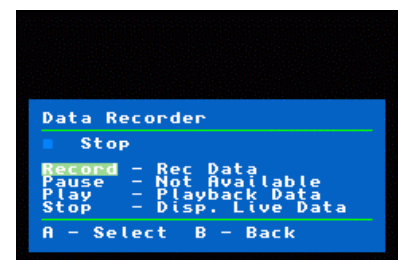

The Record function can be left running continuously. However, only the last 120 seconds of data is stored and available for playback. This data will have a time stamp associated to it.

All data channels are recorded at 50mS intervals.

PLAYBACK

Choose the display that you wish to view the recording from and display the Data Recorder Menu by pressing **START**. Select the Play option from the menu to begin playback. Playback can be paused by pressing the **A** key or by selecting Pause from the Data Recorder Menu. When playback has finished, the last data sample will be displayed on the screen along with the mode ‘End’.

STOP

To return the Gauges or Data Display back to displaying live data, bring up the Data Recorder Menu and select the Stop function.

RECORD PLAYBACK SHORT CUTS

Press the "START" button eight (8) times; you will sequentially step through the Record – Pause – Play – Stop functions.

Dtec – BC Configuration Reset

The Dtec–BC can be reset back to its original factory software configuration.

NOTE: This will overwrite any previously customized parameter setting including any setup or configuration of sensors and inputs.

1. Power up the Dtec-BC as normal and allow the Gameboy® to boot as normal.
2. Press **Select** key to display the Select Menu.
3. While on the Select Menu, press and hold the **Start** key and then press the **Select** key simultaneously.
4. Press the **A** button to reset the maps to factory default and save the changes. Press **B** to abort.

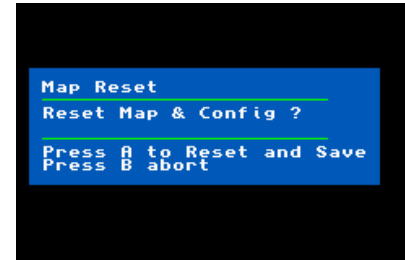

Dtec –BC software upgrades

The software version your Dtec-BC is currently running is displayed on the top right hand corner of the Setup Menu. Any future upgrade versions to the Dtec–BC software are provided free of charge and can be downloaded from the TurboXS web site.

Go to <http://www.turboxs.com/> follow the links to the Dtec web page. The latest Dtec–BC software version will be displayed on the Dtec-BC web page. If the version displayed on the web page is the same or older as that displayed on the Setup Menu do not download the available software.

Only upgrade your Dtec if you wish to utilize the new features from the latest version.

Note: You will need to save your maps to a PC prior to uploading the new firmware, as upgrading firmware will overwrite your programmed maps.

Basic Tuning Guide

General Precautions

- When modifying boost, it is critical that you ensure that the Air-Fuel ratio is always at a safe value.
- Lean mixtures can lead to detonation and engine damage.
- Be aware that increased boost may require ignition timing changes to ensure the safe operation of the engine.
- Increased boost will increase the amount of wear and stress on your engine. The increased stress, if not properly managed and monitored, may result in engine damage.
- Always avoid detonation/ping/knock when tuning. If you hear evidence of detonation/ping/knock, then reduce engine load immediately by reducing throttle.

TUNING TIPS

1. Understand what you are doing.
2. Understand what you are changing.
3. Understand why you are changing it.
4. Tune in small steps, changing one parameter at a time.
5. Apply increasing engine loads gradually.
6. Always use a good quality tuning tools such as a wide band air-fuel ratio meter and monitor air-fuel ratios closely when making changes.
7. Never tune alone, especially when road testing. Be responsible on the road.
8. If the car doesn't run well, don't try to drive through the problem.
9. Always question advice from the Internet, magazines, books, neighbors, spectators, etc.
10. Read the manual and understand it.

BOOST CONTROLLER SETUP

OPEN LOOP BOOST CONTROL

By default, the DBC boost controller is set to a gain of zero. This makes the controller run in open loop mode. The Duty cycle behaves similarly to the bleed valve style of manual boost controllers. The Spool Threshold behaves similar to the gate on a gated high performance bleed valve.

CLOSED LOOP BOOST CONTROL

When the Boost Controller Gain is set to a non-zero value, the boost controller will control boost using a closed loop control algorithm. The controller uses the incoming boost measurement from the MAP sensor against the Target Boost value to adjust the duty cycle to raise or lower the boost towards the desired target boost.

If the boost is within 0.3psi of the target, the controller will not alter the duty. This helps to improve stability when boost is close to the target.

TUNING BOOST

BASIC MODE SETUP

The following procedure is the suggested order for setting up your desired boost level:

1. Choose your boost target.
2. Adjust your duty from low to high until your maximum boost level approximates your target boost. When testing the duty cycle, ensure that you use wide open throttle and sufficient engine revs to ensure that the boost has leveled off before taking the peak boost reading. Leaving the controller gain at zero will make setup simpler.
3. Use the 'Logger Boost' display to log the boost response against RPM. Use this to determine if the boost response will require a large change in duty to ensure a flat duty response.

If the boost curve is reasonably flat once on boost, you may choose to enter the Options menu and turn on a mild amount of closed loop gain and finish setup here.

If the boost curve falls away at high RPM, or is hard to control, then Advanced Mode configuration will help control the boost.

ADVANCED MODE SETUP

The following procedure is the suggested order for setting up your desired boost level:

1. Choose your boost target. If you wish to alter your boost target across RPM, then go to Options and turn on Advanced mode now. Set the boost table with Boost Targets that follow your desired boost curve.
In some cars, it may be desirable to reduce boost at high RPM if the injectors cannot supply enough fuel at high RPM.
2. Adjust your duty on the main Boost setup window from low to high until your maximum boost level approximates your target boost. When testing the duty cycle, ensure that you use wide open throttle and sufficient engine revs to ensure that the boost has leveled off before taking the peak boost reading. Leaving the controller gain at zero will make setup simpler.
3. Use the 'Logger Boost' display to log the boost response against RPM. Go to Options and turn on the Advanced mode of operation. In the Boost Table, tune the duty cycle until the boost curve follows the target boost as close as possible.
4. Once you have setup the Targets and Duty in the Boost Table, turn on the closed loop controller by increasing the gain above zero. Set the highest gain possible that doesn't cause boost to oscillate. Boost oscillation is most noticeable when using higher gears on long hills where boost is at the Target Boost for an extended period of time. (Use a dynamometer or a long hill to ensure that vehicle speeds are kept to a safe speed.)
5. Increase Spool Threshold until the desired boost response is reached. Increase the Spool Threshold from low to high in small steps to ensure that you do not over-boost.

Product Specification

Analogue Input:	0.0 – 5.0 volt DC
Analogue Output:	0.0 – 5.0 volt DC
Digital Frequency Input:	0.0 – 5,000 Hz
Digital Duty Cycle Input:	0.0 – 100 %
Power Supply Input:	9.0 to 15.0 volts 40mA (without Gameboy®)

END OF INSTRUCTION MANUAL

Nintendo® and Gameboy® are registered trademarks of Nintendo.

This product is not licensed or endorsed by Nintendo.



www.turboxs.com